



INTRODUCTION

Welcome to the Norman family of interchangeable high-quality flash equipment and thank you for purchasing a Norman Monolight system. The utilization of larger high-duty-cycle flash capacitors and related components enables this system to be utilized for demanding commercial and portrait silver halide and digital applications that are not normally associated with monolights.

FEATURES

- **600 watt-second capacity.** The ML600 is an honest 600 watt-seconds (1500 w-s by today's advertising)
- **1/20-stop repeatability at full power.** Holds this tolerance with line voltages from 105 to 125 volts.
- **250 watt quartz modeling lamp** with fan cooling.
- **Digital controls with LED display.** Adjustable in 1/10-stop increments.
- **Error condition diagnostic readouts** via internal software, as displayed in the LED arrays (page 7).
- **Automatic thermal protection** (page 7).
- **Interchangeable with over 100 Norman accessories and light modifiers** with adapter ring (part no. R9113).
- **Full two year limited warranty**, including parts and labor.



**Instruction
Manual**

ML600 Monolight

IMPORTANT SAFEGUARDS

In accordance with UL122 specifications for photographic equipment.

When using your photographic equipment, basic safety precautions should always be followed, including the following:

1. Read and understand all instructions.
2. Care must be taken as burns could occur from touching the flashtube or modeling lamp.
3. Do not operate the appliance with a damaged cord or if the appliance has been dropped or damaged, until it has been examined by a qualified service technician.
4. If an extension cord is necessary, a cord with a suitable rating should be used. Cords rated for less amperage than the appliance may overheat. Care should be taken to arrange the cord so it will not be tripped over or pulled.
5. When practical, unplug the appliance from the electric outlet when not in use. Never yank the cord to pull it from the outlet. Grasp the plug and pull to disconnect.
6. To avoid electrical shock hazard, do not disassemble this appliance, but take it to a qualified service technician when service or repair work is required. Incorrect reassembly could cause an electric shock hazard when the appliance is subsequently used.
7. CAUTION – Designed for indoor use only. Do not operate outside in the rain or in inclement weather or in the presence of standing water.
8. The use of an accessory attachment not recommended by the manufacturer may cause a risk of fire, electric shock, or injury to persons.
9. Always connect this appliance to a grounded outlet.
10. Disconnect the unit from its source of supply before replacing the flashtube or modeling lamp.

Warning: Changes or modifications to this unit not expressly approved by the party responsible for compliance could void the user's authority to operate the equipment.

Note: This equipment has been tested and found to comply with the limits for a Class A digital device, pursuant to Part 15 of the FCC Rules. These limits are designed to provide reasonable protection against harmful interference when the equipment is operated in a commercial environment. This equipment generates, uses, and can radiate radio frequency energy and, if not installed and used in accordance with the instructions, may cause harmful interference to radio communications. Operation of this equipment in residential area is likely to cause harmful interference in which case the user will be required to correct the interference at their own expense.

Warning: Never operate this equipment with the flashtube cover installed. This will cause damage to the unit due to overheating.

UNPACKING AND QUICK START

Carefully unpack and remove all parts from the shipping carton(s). Do not discard or destroy any packing materials until all parts of the equipment have been inspected, assembled, and working properly.

Inspect all parts for damage due to shipping. If any damage is found, contact the delivery carrier immediately. Claims should be made to the delivery carrier before destroying shipping carton(s).

Place the ML600 unit on a stable light stand that will properly support the weight of the ML600 and any accessories that will be attached. The ML600 stand adapter is designed to accommodate light stand tops from 3/8" to 5/8" studs. Secure the ML600 unit to the light stand with the threaded knob.

The Modeling Lamp and Flashtube are shipped uninstalled to avoid damage. To avoid electrical shock, always unplug unit from AC power when installing or removing modeling lamp or flashtube. Use a clean glove or cloth to handle flashtube and modeling lamp to avoid transfer of body oils to domes (this can significantly diminish the life of the lamp). Carefully install the modeling lamp into the socket, push and turn the lamp until it is seated properly. Carefully install the flashtube making sure that it is seated fully into the sockets. This avoids arcing that can cause premature failure of the sockets.

Install the reflector to the front of the unit. Place the top of the reflector under the top lip first and then just press the bottom into place. (The reflector should snap into place.) To remove the reflector simply squeeze the two arms at the bottom of the unit together and swing the reflector away from the unit.

With the ML600 power switch off, plug the AC cord into the unit and then into a 3-prong grounded receptacle. Turn the power switch on. When the ready light turns on the unit has reached the power level displayed on the control panel.

Flash Rate

This unit is designed to quickly recharge to full power in about 2 seconds. However, continuous rapid flashing of the unit, without resting, may overheat and damage the flashtube and internal components. At maximum power, the recommended continuous cycle rate is 12 seconds between flashes. In addition, up to 4 minutes of rapid firing at a 4 second flash rate is possible. By lowering the power and/or increasing the time between flashes you can extend the duration of rapid flashing. Alternatively, the cycle rate may be increased by lowering the power and/or decreasing the duration of rapid flashing.

CONTROL PANEL / OUTLETS / BASIC OPERATION

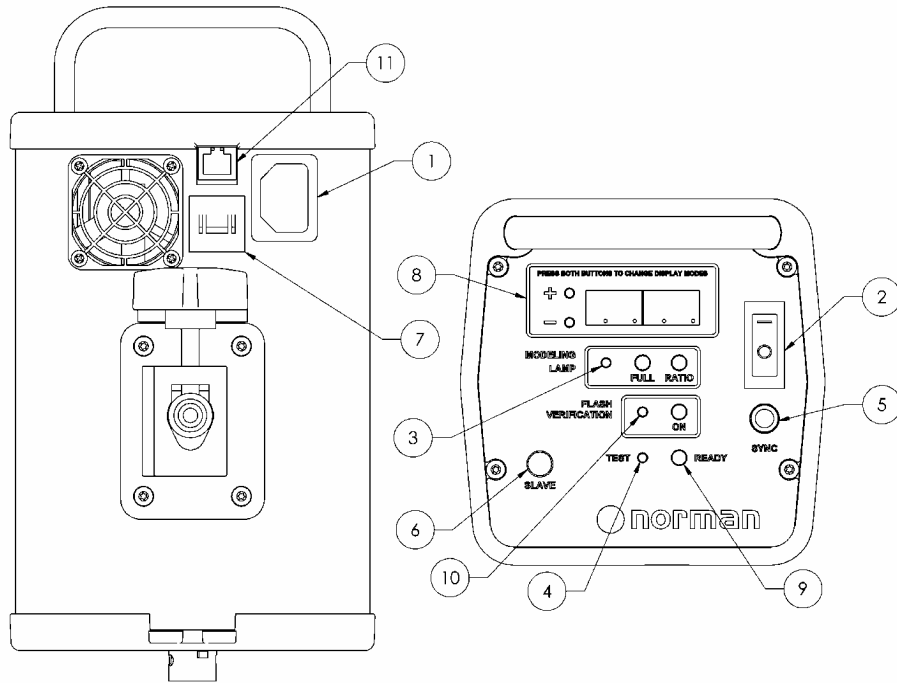

1. AC Power Inlet

Connects to the AC power cable. The AC input is 115 volts, 60 Hz. The unit is voltage stabilized to provide 1/20-stop full power repeatability with AC line voltage fluctuations of 20 volts (105-125 volts).

2. Power Switch

Switches the AC power on/off. A memory circuit retains the output settings when the unit is switched back on or when the AC power is interrupted.

3. Modeling Lamp

Depress the pushbutton switch to toggle between the three modeling lamp modes:

FULL - The modeling lamp is at full brightness regardless of the flash power setting.

RATIO - The modeling lamp will automatically ratio (track) with the flash power setting.

OFF - The modeling lamp is off (indicated by both the Full and Ratio LED's off).

4. TEST Button

The unit can be flashed by depressing the TEST button. When changing power levels, power can be discharged through the flashtube instantly with this button instead of waiting for the power to be bled through the discharge resistor of the internal circuitry.

5. SYNC Outlet

The camera connects to this outlet via the R4155 Sync Extension Cord (included). The socket (female) end of the Sync Extension Cord connects to the camera sync cord (not included). Most 35mm and 120mm cameras utilize a standard "PC" sync cord which is available through your photo supply store.

Proper polarity is important with cameras that utilize grounded shutter switch circuits (cameras that utilize PC cords). If the unit does not flash on initial set-up the polarity may be reversed. To achieve the correct polarity – Reverse the camera sync cord at the point where it joins the Sync Extension Cord. This establishes a common ground between the camera body and the flash unit. If the polarity is incorrect the unit could self-flash or flash intermittently.

6. Photo Eye (Slave)

Permits remote triggering from other flash units. The Photo Eye is automatically disabled when a 1/4" sync plug is inserted in the SYNC outlet.

7. RESET 10 Amp Circuit Breaker

Automatically protects the flash circuit against excessive overloads. When activated, it will pop out about 1/4" and the unit will become inoperative. To reset, wait at least 30 seconds and depress the RESET button. If the circuit breaker continues to activate, consult the factory or your authorized Norman service center.

8. Flash Power +/- Pushbutton Switches and LED Display

Controls the unit output in 1/10-stop increments over a 5-stop range plus "full" (6-stops total). Tap the + or – pushbutton switch for each 1/10-stop change. Hold the pushbutton switch down and the change accelerates for convenience. Once the approximate power level is obtained, tap the pushbutton switches until the desired setting is obtained.

The LED can display the output in two modes: f-stop reduction or watt-seconds power level. Press both the + and – pushbuttons at the same time for at least 2 seconds to change display modes.

Error conditions are displayed on the LED, as outlined on page 7.

9. Ready Light

The unit is fully charged when the Ready Light is on. At minimum power (18.75 w-s) the recharge time is approx. 0.5 seconds, and at maximum power (600 w-s) the recharge time is approx. 2 seconds. The unit may be flashed before it reaches full charge.

10. Flash Verification

Flash verification will visually indicate when the unit has flashed. The modeling lamp will cycle on and off, then return to its previous state.

This function can be enabled / disabled by toggling the Flash Verification pushbutton switch.

11. Computer Control Modular Jack

ADVANCED OPERATION

Alarm System

In the event of a misfire the LED display will blink bFL (see page 7). The alarm system is reset automatically by flashing the unit or by pressing any button on the control panel.

Thermal Protection

The ML600 is protected with an internal overtemp cutout. In the event of an overtemp, the modeling light will be disabled.

SERVICE

Should not be attempted by user. **Consult an authorized Norman Service Center.**

Modeling lamp or flashtube replacement. Always unplug unit and discharge stored energy by pressing the Test button. Wait 10 minutes for any residual charge on the main capacitors to bleed off and let the flashtube and modeling lamp cool before handling. Always handle modeling lamp with clean gloves or cloth to avoid transfer of body oils to lamp dome. Carefully remove old flashtube and/or modeling lamp and replace with new.

Never place metal object or fingers into modeling lamp or flashtube sockets.

DIAGNOSTIC TROUBLESHOOTING / ERROR CODES

This information can assist the operator in determining the source of a malfunction and it can assist an authorized Norman service center in servicing a Norman Monolight. These codes flash on the LED Display, signifying the following:

General Errors

bFL – Indicates a misfire. Check if flashtube is installed, flashtube may need replacement.

hot – Indicates internal temperature has exceeded normal operating limits. Modeling lamp will be disabled and automatically enabled when internal temperature returns to normal operating range.

GENERAL TROUBLESHOOTING

Unit will not flash:

- Flashtube is not installed properly. (see page 4)
- Sync cord polarity not correct (see 'SYNC Outlet' page 6)

Unit does not turn on:

- Check power cord
- Check circuit breaker

Photo Eye does not flash unit:

- Sync cord is plugged in (see page 'Photo Eye' page 6)
- Trigger flash is out of range

Modeling light will not turn on.

- Modeling lamp is not installed properly (see page 4)
- Modeling lamp is broken
- Modeling lamp is turned off. Check the control panel switches (see page 5)

Note: If you are still experiencing trouble after checking the above general troubleshooting guideline contact Photo Control Customer Service.

SPECIFICATIONS

Power:	600 W-S
Recycle Time:	2 sec.
Flash Duration:	1/1200 sec. (full)
Power Control:	Full to -5 F-Stops
Modeling Lamp:	250W
Modeling Lamp Control:	Off, Ratio, Full
Trigger:	Built-in Photo-eye, ¼" Sync Jack, Test Button
Supply Voltage:	105-125 VAC, 60Hz, 10A
Consumption:	10A
Voltage Stabilization:	+/- 1%
Overload Protection:	10A Circuit Breaker
Weight:	6.14 Lbs.
Flashtube:	Quartz, full envelope
Guide Number:	135 at 10 ft., ISO100, Bare Bulb
Sync Voltage:	6 VDC

norman

Manufactured by **Photo Control Corporation**

www.photo-control.com

Email: pcc-info@photo-control.com
4800 Quebec Avenue North, Minneapolis, MN 55428
(763) 537-3601 Voice, (763) 537-2852 Fax
(Pub. No. 335-028C)

For Norman ML400R and ML600R Monolights Supplied with the PocketWizard™ Receiver

The ML400R and ML600R Incorporate a built-in PocketWizard™ receiver which is internally wired for simple operation.

No Batteries are required.

Operation

The PocketWizard™ enabled ML400R and ML600R “listens” for wireless data transmissions from a PocketWizard™ transmitter upon power up for the first 30 seconds of operation. The ML400R and ML600R automatically scans continuously through the 4 channels and if it detects continuous valid trigger signals for 4 seconds on a particular channel it will set itself to operate on that channel. To do this, press and hold the “test” button on your transmitter. If no valid trigger data is found within the first 30 seconds from power up, the unit will set itself to operate on the last channel used prior to the previous power down.

When you apply power to the ML400R or ML600R, the radio receiver *will not* respond for the first 30 seconds, unless you “teach” it a new channel (by pressing and holding the “test” button on your transmitter). After learning, the unit will flash to indicate it is ready on the new channel.